

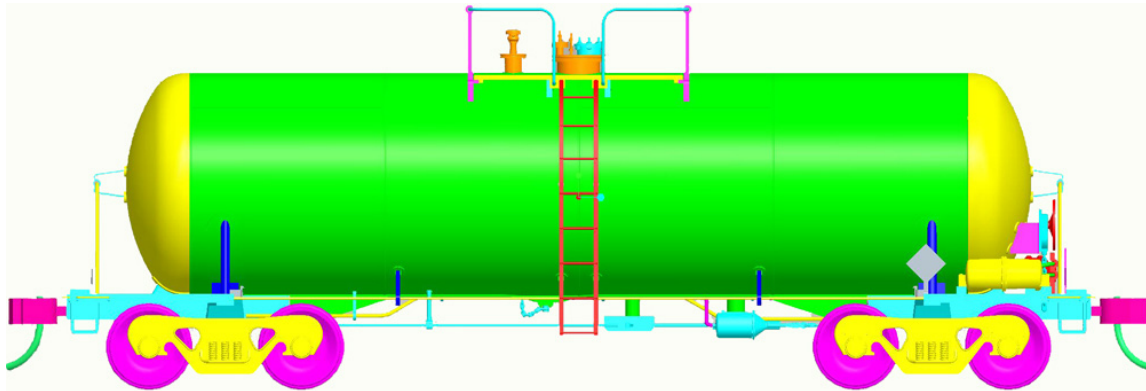

Announced: 9-16-08  
**Orders Due: 10-10-08**  
 ETA: April 2009

# 13,600 Gal Acid Tank Car



Era: 1979 to Present

- All-new tooling of a prototype never offered before in HO
- Two different body “phases” (early and late)
- Different top platforms as appropriate per prototype
- Different brake systems as appropriate per prototype
- Many separately applied details
- McHenry® scale double-shelf knuckle spring couplers
- \*\* Final product may differ slightly from drawings
- Highly detailed, injection-molded body
- Etched metal walkways
- Separate wire grabs and handrails
- Different end sills as appropriate per prototype
- Razor-sharp painting and printing

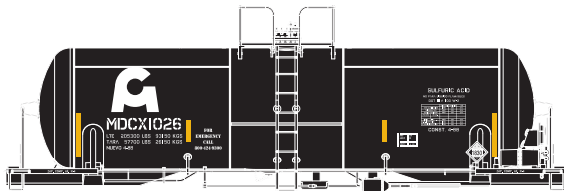

___ 96101 MDCX #1026	\$27.98
___ 96102 MDCX #1054	\$27.98
___ 96103 MDCX #1083	\$27.98
___ 96104 MDCX #1092	\$27.98

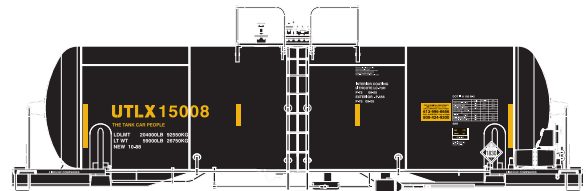

___ 96109 UTLX (Black) #15008	\$27.98
___ 96110 UTLX (Black) #15073	\$27.98
___ 96111 UTLX (Black) #125018	\$27.98
___ 96112 UTLX (Black) #125046	\$27.98

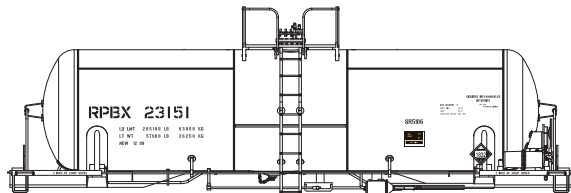

___ 96105 RPBX #23151	\$27.98
___ 96106 RPBX #23155	\$27.98
___ 96107 RPBX #23160	\$27.98
___ 96108 RPBX #23162	\$27.98

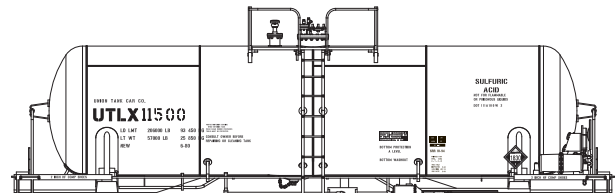

___ 96113 UTLX (White) #11500	\$27.98
___ 96114 UTLX (White) #11567	\$27.98
___ 96115 UTLX (White) #11580	\$27.98
___ 96116 UTLX (White) #11594	\$27.98
___ 96100 Undecorated	\$27.98

Athearn Trains • 1550 Glenn Curtiss Street • Carson, CA • 90746  
 310-763-7140 • fax 310-763-7449 • www.athearn.com